

UNESCO

Refurbishment of an occupied heritage office building.

CLIENT

UNESCO

TEAM

Patriarche (Architecture, MEP Engineering, EBO, Cost)

Partners:

Ragot Gilles, Eckersley O'Callaghan, MDP, Omega Alliance, Lamoureux, and Casso & Associés

KEYPOINTS

Renovation of facades.

Taking into account the existing heritage.

Conservation of geometries and atypical structures.

Thermal, hygrometric and acoustic comfort.

Implementation of PMR accessibility.

Creation of gardens.

ENVIRONMENTAL PERFORMANCE

TARGET : BBC Effinergie Rénovation

ENERGY : 63% Ubat improvement and 70% improvement in regulatory energy consumption.

REUSE of materials (between 7 and 15%).

Located in the 15th arrondissement of Paris, close to the Place de Fontenoy headquarters, UNESCO Building V, designed by Bernard Zehrffuss and Jean Prouvé and inaugurated in 1970, is a truly exceptional operating site, thanks to its near-original state of preservation.

Tasked with this heritage renovation project, Patriarche's teams are working on its preservation and reinterpretation, with a view to energy efficiency. This rehabilitation is being carried out on an occupied site, in a complex urban context.

The program includes :

- Bringing the building up to safety and accessibility standards, and replacing all technical installations to meet comfort, energy-saving and low-carbon building criteria;
- restoration of the original façade, reuse and overall enhancement of the building's heritage;
- requalification of the interior spaces of the hall, offices and washrooms, and enhancement of the outdoor spaces of the patio and Miollis garden.

Ultimately, the renovated building will meet the targets set by Paris' territorial Climate Energy Plan, with an HPE BBC-Effinergie renovation 2009 label, in order to limit the building's energy consumption.

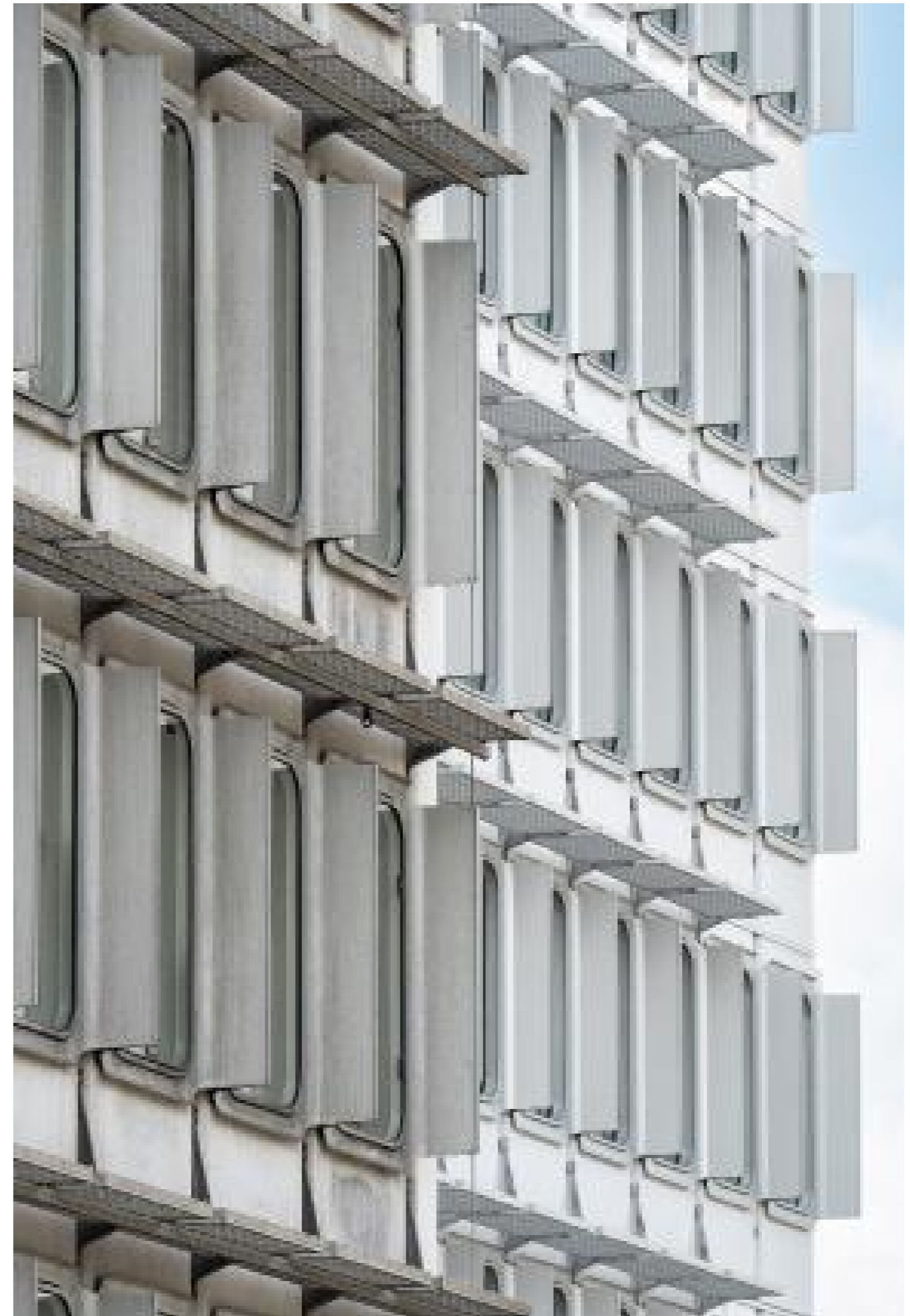

Typology
Refurbishment, Office

Surface area
16,711 m² of floorspace

Construction cost
33 M€

Location
Paris, France

Status
Delivery 2023

Allocation mode
Public Works Management

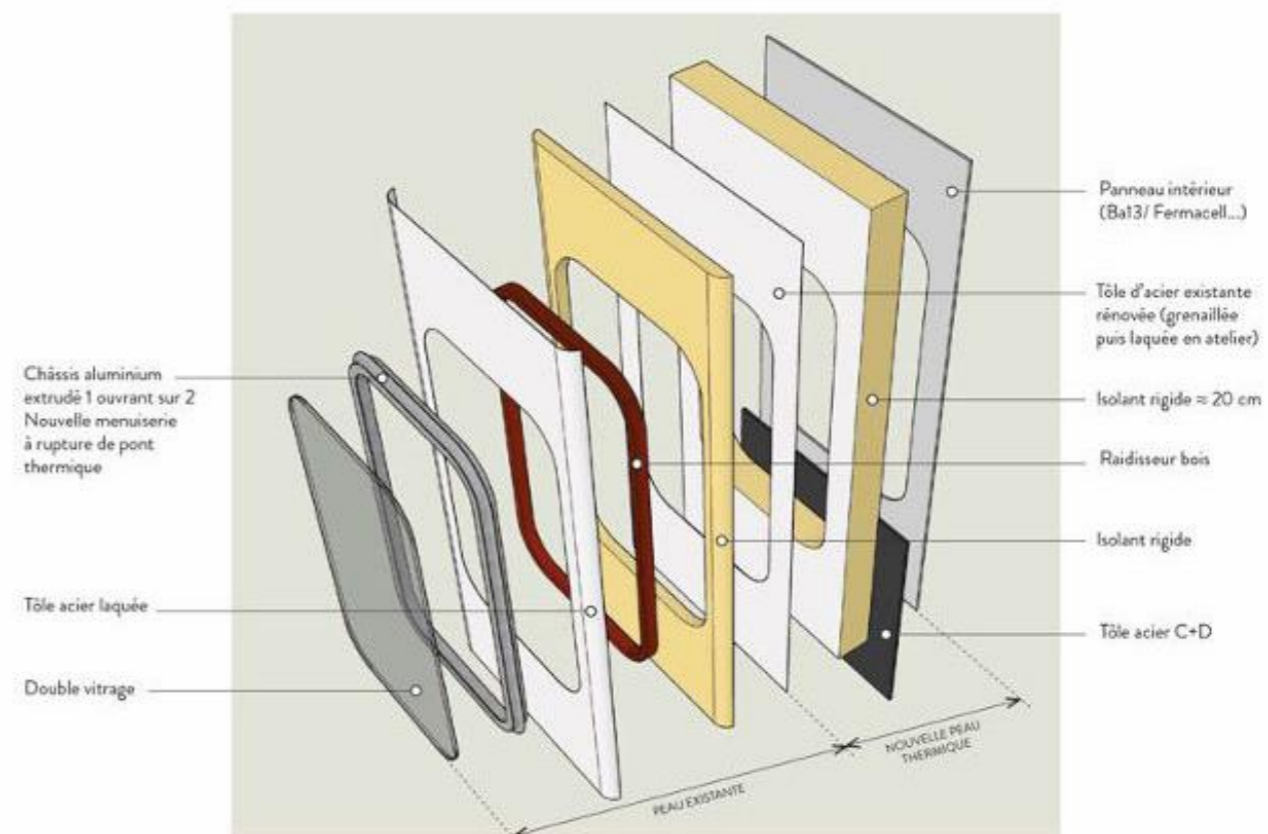
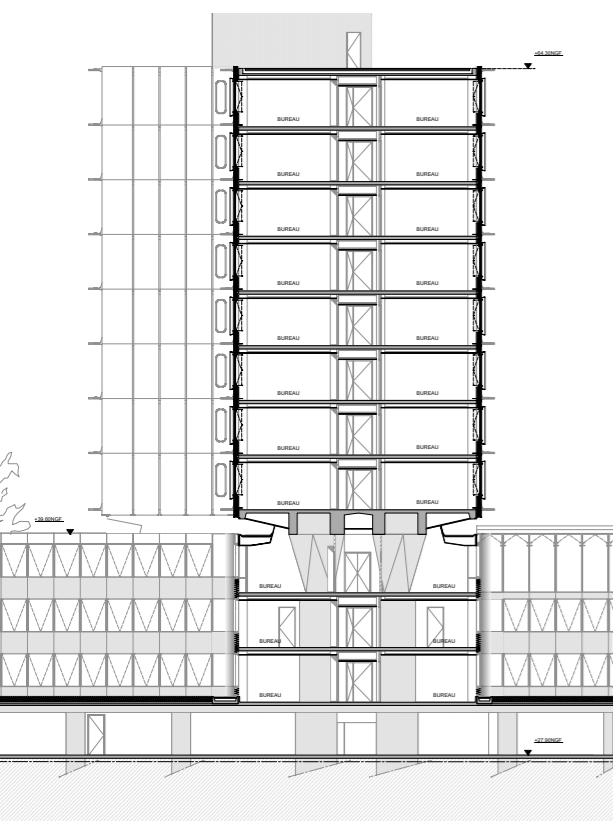

PRINCIPE PROJETE D'UN PANNEAU DE FACADE

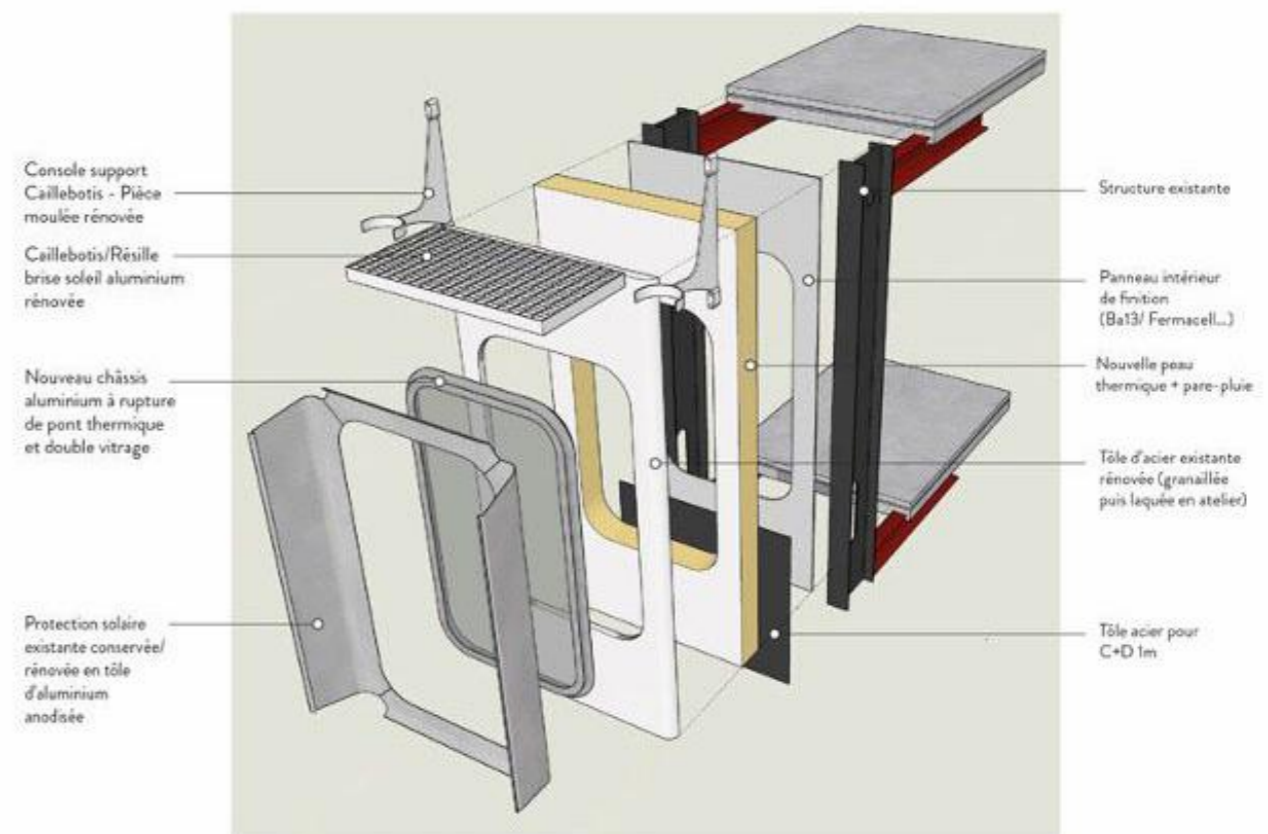

PRINCIPE PROJETE D'UNE TRAME DE FACADE



UNESCO

Typology
Refurbishment, Office

Surface area
16,711 m² of floorspace

Construction cost
33 M€

Location
Paris, France

Status
Delivery 2023

Allocation mode
Public Works Management